

## Builder Series Programmable Thermostats

**MODEL 2000** Single Stage Heat / Cool  
Conventional and Heat Pump

**MODEL 2200** Multi-Stage 2 Heat / 1 Cool  
Conventional and Heat Pump

**Before Installing, Programming or Operating,  
PLEASE READ ALL INSTRUCTIONS**

- |                                      |  |
|--------------------------------------|--|
| <b>1 Specifications</b>              | <b>5 Additional Operation Features</b> |
| <b>2 Installation</b>                | <b>6 Troubleshooting</b>               |
| <b>3 Testing Your New Thermostat</b> | <b>7 Wiring Diagrams</b>               |
| <b>4 Programming User Settings</b>   |  |

## WARNING

### Important Safety Information

- Always turn off power to the air conditioning or heating system prior to installing, removing, cleaning or servicing thermostat.
- This thermostat is a dual power thermostat and either requires 24 Volts AC Power or two (2) properly installed "AA" alkaline batteries for normal operation and control of the heating or cooling system.
- This thermostat also requires two (2) properly installed "AA" alkaline batteries to retain clock setting in the event of loss of AC Power due to a power outage or rolling blackouts when used as a hardwired thermostat.
- This thermostat should only be used as described in this manual. Any other use is not recommended and will void the warranty.

## 1 Specifications

- Electrical Rating: 24 Volt AC (18-30 Volt AC)
  - 1 amp maximum load per terminal
  - 2 amp total maximum load (all terminals) (Model 2000)
  - 3 amp total maximum load (all terminals) (Model 2200)
- Control Range: 45° - 90° F (7° - 32° C)
- Accuracy: +/- 1° F (+/- .5° C)
- AC Power: 18-30 Volt AC
- DC Power: 3.0 Volt DC (2 AA Alkaline batteries included)

## 1 Specifications *cont.*

- Model 2000:** Compatibility with low voltage single stage gas, oil or electric heating or cooling systems, including single stage heat pumps; can also be used on 250mv to 750mv millivolt heating only systems.
- Model 2200:** Compatibility with low voltage multi-stage gas, oil or electric heating or cooling systems, including multi-stage heat pumps.
- Model 2000 Terminations:** Rc, Rh, B, O, Y, W, G, C
- Model 2200 Terminations:** R, O, B, C, Y1, E/W1, G, W2

## 2 Installation

### Replacing Existing Thermostat

*Most thermostats have three parts:*

- The cover, which may snap or hinge over the existing thermostat.
- The electronics or body, which controls the existing system.
- The sub-base, where the wires attach through the wall to the existing system.

- Always turn off power to the air conditioning or heating system prior to removing existing thermostat.
- Carefully remove the cover and electronics body from the old thermostat sub-base. Depending on the brand, these parts may pull off or need to be unscrewed. The old sub-base should remain wired and on the wall until steps 4 and 5.
- Label every old wire with the letter of the connection to which the wire is attached. Example letters are R, M, Y etc. Depending on the brand of the old thermostat, your letters may be different.
- After labeling the old wires, loosen each connection and remove them from old sub-base. Secure the wires to prevent them from slipping into the hole in the wall.
- Remove the old sub-base from the wall, again being careful that the wires do not slip into the hole in the wall.
- Use the chart below to determine the new thermostat connections. As an example, if the old thermostat had a G connection, it goes to G on the new thermostat. Note the chart includes information for both the Braeburn 2000 and 2200 series thermostats. Be sure to use the correct column for the new thermostat.

Old Terminal from Existing Thermostat	New Terminal for New Thermostat (Model 2000)	New Terminal for New Thermostat (Model 2200)	Terminal Description
V or Rc	Rc		Cooling Transformer
M, 4, Rh, or R	Rh		Heating Transformer
R, V-VR or VR-R		R	24 VAC
B	B	B	Reversing Valve (Heating)
O	O	O	Reversing Valve (Cooling)
Y, Y1 or M	Y	Y1	Cooling or Compressor for HP System
E, H, W, W1 or 4	W	E/W1	1st Stage Heat or Emergency Heat
G or F	G	G	Fan Control
C, X or B	C	C	24 VAC Common
W1, W2 or W-U		W2	2nd Stage Heat

## 2 Installation *cont.*

**NOTE—MODEL 2000:** This thermostat is designed for use with 24 Volt-AC low voltage single stage gas, oil or electric heating or cooling systems, including single stage heat pumps and can also be used on 250mv to 750mv millivolt heating only systems. Do not use this thermostat on applications with voltages above 30 Volts AC.

**NOTE—MODEL 2200:** This thermostat is designed for use with 24 Volt-AC low voltage multi-stage gas, oil or electric heating or cooling systems, including multi-stage heat pump systems. Do not use this thermostat on applications with voltages above 30 Volts AC.

### Installing New Thermostat

**NOTE:** If installing this thermostat in a new installation, locate the thermostat 4 to 5 feet above the floor in accordance with applicable building codes. Install the thermostat in a location that provides good airflow characteristics and avoid areas behind doors, near corners, air vents, direct sunlight or heat generating devices. Installation in these areas could impact thermostat performance. Wiring must conform to all building codes and ordinances as required by local and national code authorities having jurisdiction.

1. Always turn off power to the air conditioning or heating system prior to installing thermostat.
2. Place system switch on front of thermostat to the **OFF** position.
3. Place fan control switch on front of thermostat to the **AUTO** position.
4. Remove front of thermostat body from sub-base by pressing release latch on bottom of thermostat.
5. Place the thermostat sub-base against wall in the desired thermostat location.
6. Guide thermostat wires through hole in sub-base and continue to hold against wall.
7. Mark placement of mounting holes as appropriate and drill using a 3/16" drill bit.
8. Gently tap supplied plastic anchors into the holes in the wall.
9. Place the thermostat sub-base against the wall in the desired location, making sure the mounting holes are aligned and the thermostat wires are inserted through the opening in sub-base.
10. Fasten sub-base to wall using supplied screws.
11. Connect wires to quick wiring terminal block using the new terminal designations. Refer to *Wiring Diagram* in section 7 of this manual for assistance.
12. Make sure all of the wire connections are secure and are not touching any other terminal to prevent electrical shorts and potential damage to the thermostat.
13. Turn the front thermostat body over, exposing the rear view of the circuit board.
14. Locate the internal °F / °C switch on the circuit board. Using your fingers, flip the switch toward the preferred temperature °F / °C scale.
15. Locate the internal fan option switch, **HG** (Gas) / **HE** (Elec) on the circuit board. This switch controls the heating system fan delay. Select gas for gas or oil fired systems. This will allow the furnace to run for a few seconds before initiating the fan. Select electric for electric heat systems that require the fan to come on immediately. Using your fingers, flip the switch toward **HG** (Gas) or **HE** (Elec).
16. Locate the internal **NORM** / **HP** switch on the circuit board. This switch configures the thermostat for conventional (NORM) heating and cooling systems or heat pump (HP) systems. Using your fingers, gently flip the switch toward **NORM** or **HP**. (continued on page 3)

## 2 Installation *cont.*

17. Attach front body of thermostat to sub-base of thermostat, being careful to align the terminal pins on the front body with the terminal block on the sub-base.
18. Open front thermostat door and open battery compartment door.
19. Install two new "AA" alkaline batteries. Locate the positive (+) ends of the batteries and match them with the positive (+) terminals located in the battery compartment. Close battery compartment.
20. Restore system power so you can test installation.

**NOTE:** If batteries were installed prior to accomplishing steps 14 through 16, you will need to reset the thermostat to register thermostat switch configurations prior to programming any user settings. Gently press the **RESET** button on the front of the thermostat using a paperclip or a small pencil tip.

## 3 Testing Your New Thermostat

### **WARNING!** Read *BEFORE* Testing

- Do not short (or jumper) across terminals on the gas valve or at the heating or cooling system control board to test the thermostat installation. This could damage the thermostat and void the warranty.
- Do not select COOL mode if the outside temperature is below 50° F (10° C). This could damage the controlled cooling system and cause personal injury.
- This thermostat includes an automatic compressor protection feature to avoid potential damage to the cooling system from short cycling. This thermostat automatically provides a 5-minute delay after turning off the cooling or heating system output to protect the compressor.

**NOTE:** Test your thermostat prior to programming any user settings. Pressing the **RESET** button will erase any user entries previously programmed and return them to their default values.

1. Place the system switch in the **HEAT** position.
2. Press and hold the **▲** button on the keypad until the set point temperature setting is a minimum of 3 degrees higher than the current room temperature. The heating system should start within several seconds. The fan may not turn on immediately due to the heating system built-in fan delay.
3. Place the system switch in the **OFF** position. The heating system should stop within several seconds with conventional heating or cooling systems. On heat pump systems you must wait 5 minutes for the automatic compressor short cycle protection period to expire, or press the **RESET** button to bypass this feature for initial testing purposes. Pressing the **RESET** button will erase any user program settings.
4. Place the system switch in the **COOL** position.
5. Press the **▼** button on the keypad until the set point temperature is a minimum of 3 degrees lower than the current room temperature.
6. The cooling system should start within several seconds. Place the system switch in the **OFF** position. The cooling system should stop within a few seconds.
7. Place the fan switch in the **ON** position. The system blower should start.
8. Place the fan switch in the **AUTO** position. The system blower should stop.

**NOTE:** When you place the system switch in the **COOL** or **HEAT** modes of operation, the appropriate indicator will also appear in the LCD display when the system is running. When you place the system switch in the **OFF** mode, the display will indicate **OFF**.

## 4 Programming User Settings

### Default Thermostat Settings

Function	Status After Reset
Operation Mode	Normal Operating Mode
Temperature Hold	Permanent and Temporary Hold Cleared
Clock	12:00 p.m., Monday
Room Temperature	70° F (21.0° C), to be renewed within 5 seconds
Set Point Temperature	According to System Switch 62° F (17.0° C) for Heat and Off 83° F (28.0° C) for Cool
Temperature Scale	°F or °C dependent on switch setting
Operating Program	DAY program, Monday
Low Battery Warning	Off, to be renewed within 5 seconds
1st Stage Differential	0.5° F (0.25° C)
2nd Stage Differential	2° F (1.0° C)
Short Cycle Protection Timer	Reset
Output Relays	Off
Filter Check Monitor	0 days-off
Extended Hold	Indefinite
Adaptive Recovery Mode	Reset

### Setting Current Time of Day and Day of Week

**NOTE:** It is important for you to set the current time of day (note AM/PM indicator in display), and the current day of week correctly to avoid problems with program execution.

1. When in normal operating mode, press the **DAY/TIME** keypad button. The LCD display will be cleared except for the time, am/pm indicator and the day of the week. The hour portion of the time will flash. Press the **▲** or **▼** button to set the current hour.

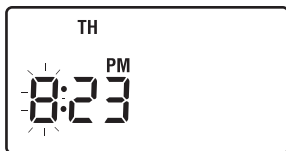

2. Press the **DAY/TIME** button again. The minute portion of the time will flash. Press the **▲** or **▼** button to set the current minute.
3. Press the **DAY/TIME** button again. The day of the week indicator will flash. Press the **▲** or **▼** button to set the current day of the week.
4. Press the **DAY/TIME** button again and the thermostat will return to normal operating mode.

**NOTE:** The thermostat will return to normal operating mode automatically after 30 seconds if no key is pressed. It will also return to normal operating mode immediately if the **RETURN** button is pressed.

## 4 Programming User Settings *cont.*

### Setting Thermostat User Options

The default user options are compatible with most systems and applications. They are normally set at the time of installation and usually do not require modification under normal operating conditions. If you wish to change these settings, simply follow the instructions below.

#### Setting First Stage Differential

**NOTE:** The temperature differential settings are the same for both the heating and cooling systems.

The default setting is 0.5° F (0.25° C). The room temperature must change .5° F (0.25° C) from the set point temperature before the thermostat will initiate the system in heating or cooling.



1. In normal operating mode, press and hold the **RETURN** button for 4 seconds. The LCD display will show "SET D1 x", where "x" equals the °F / °C differential setting. This is the current first stage differential setting.
2. Press the **▲** or **▼** buttons to set the first stage differential to your desired setting of .5°, 1°, or 2° F (.25—displayed as .3°, .5° or 1° C).

**NOTE – MODEL 2000:** Once you have finished setting the first stage differential, you can wait 15 seconds and the thermostat will return to the normal operating mode. Or you can press the **RETURN** button to return to normal operating mode.

**NOTE – MODEL 2200:** If you do not wish to change the second stage differential, wait 30 seconds and the thermostat will automatically return to the normal operating mode.

#### Setting Second Stage Differential (Model 2200)

The default setting is 2° F (1.0° C). The room temperature must change 2° F (1.0° C) in addition to the first stage differential setting before the thermostat will initiate the second stage of the system in heating.



1. Press and hold the **RETURN** button again and the LCD display will show "SET D2 x", where "x" equals the °F / °C differential setting. This is the current second stage differential setting.
2. Press the **▲** or **▼** buttons to set the second stage differential to your desired setting of 2°, 3°, 4°, 5° or 6° F (1°, 1.5°, 2°, 2.5° or 3° C).

**NOTE – MODEL 2200:** Once you have finished setting the second stage differential, wait 30 seconds and the thermostat will return to the normal operating mode.

**NOTE:** To erase all user program settings, gently press **RESET** button using a paper clip or a small pencil tip. This will return all thermostat settings to their default values, erasing all program settings entered by the user.

## 4 Programming User Settings *cont.*

### Setting the Extended Hold Time (see also section 5)

The default setting is Long (indefinite) Hold. If the HOLD feature is activated, the current set point will be held until HOLD is released.



- In normal operating mode, press and hold the **RETURN** button for 4 seconds. Press **RETURN** again to skip past differential setting. The display will show "HOLD LG", where **LG** is indefinite hold.
- Press the **▲** or **▼** button to change the Extended Hold time from indefinite (**LG**) to 24 hours (**SH**).
- Press the **RETURN** button again to set the Filter Check Monitor or wait 30 seconds for the thermostat to return to the normal mode.

### Setting Filter Check Monitor (see also section 5)

The default setting is 0 days (Filter monitor disabled).



- In normal operating mode, hold the return button for 4 seconds. Press **RETURN** button repeatedly until "**XXX SET FILT**" is shown where **XXX** is the Filter Monitor interval.
- Press the **▲** or **▼** button to change the Filter Monitor interval to the desired value of 0 (disabled), 30, 60, 90, 120, or 180 days.
- Press the **RETURN** button again to set the Adaptive Recovery Mode or wait 30 seconds for the thermostat to return to the normal mode.

### Setting Adaptive Recovery Mode (ARM™) (see also section 5)

The default setting is ON (Adaptive Recovery Mode enabled).



- In normal operating mode, press and hold the **RETURN** button for 4 seconds. Press **RETURN** repeatedly until "**SET XXX**" is shown where **XX** is the Adaptive Recovery Mode.
- Press the **▲** or **▼** button to change the Adaptive Recovery Mode to either **ON** or **OFF**.
- Press the **RETURN** button again or wait 15 seconds for the thermostat to return to the normal mode.

### Setting Your Energy Saving Programs – Tips Before Starting

- It is important for you to set the current time of day (note the AM/PM indicator in the display), and the current day of week correctly to avoid problems with program execution. This must be done prior to entering any program settings.
- The heating and cooling programs have both separate set point times and set point temperatures.

## 4 Programming User Settings *cont.*

- This thermostat is pre-programmed with weekday and weekend set point times and temperatures recommended by the Environmental Protection Agency and the U.S. Department of Energy in their ENERGY STAR® program. These settings provide efficient energy savings during normal heating and cooling modes of operation. If you wish to use the settings in the table, no further programming is necessary. Review these time and temperature settings prior to establishing your personal program settings to maximize your savings, and minimize programming requirements.

	Weekday	Weekend
MORN	Time: 6:00 am	Time: 6:00 am
	Heat: 70° F (21° C)	Heat: 70° F (21° C)
	Cool: 75° F (24° C)	Cool: 75° F (24° C)
DAY	Time: 8:00 am	Time: 8:00 am
	Heat: 62° F (17° C)	Heat: 70° F (21° C)
	Cool: 83° F (28° C)	Cool: 75° F (24° C)
EVE	Time: 6:00 pm	Time: 6:00 pm
	Heat: 70° F (21° C)	Heat: 70° F (21° C)
	Cool: 75° F (24° C)	Cool: 75° F (24° C)
NIGHT	Time: 10:00 pm	Time: 10:00 pm
	Heat: 62° F (17° C)	Heat: 62° F (17° C)
	Cool: 78° F (26° C)	Cool: 78° F (26° C)

- Make sure you place the system switch in the **HEAT** or **COOL** modes of operation as appropriate. You should not enter a program in the **OFF** position.
- When you place the system switch in the **COOL** or **HEAT** modes of operation, the appropriate indicator will also appear in the LCD display when the system is running.
- When you place the system switch in the **OFF** mode the display will indicate **OFF**.

### Programming Overview

Your thermostat contains separate Weekday and Weekend Program Groups that allow you to change the daily set point times and temperatures to meet your individual schedule needs.

**Weekday** - allows you to program all the weekdays (M, TU, W, TH, F will show in display) at the same time. Allows programming times and temperature settings for four set points (MORN, DAY, EVE and NIGHT) to meet your weekday schedule needs.

**Weekend** - allows you to program all the weekend days (SA, SU will show in the display) at the same time. Again allows programming times and temperature settings for four set points (MORN, DAY, EVE and NIGHT) to meet your weekend schedule needs.

### Entering Your Program

- Place the system switch in the **HEAT** mode of operation.
- Press the **PROG** button to enter Program setting mode. The **MORN** set point of the Weekday Program Group will be displayed. The display will show **M, TU, W, TH, F** to indicate the Weekday group is being programmed. The hour portion of the set point time and the AM/PM indicator will be flashing. (*cont. on page 8*)



## 4 Programming User Settings *cont.*

3. Press the **▲** or **▼** button to change the time to the desired hour in 1 hour increments. Press the **PROG** button to save. The minute portion of the set point time will begin flashing.
4. Press the **▲** or **▼** button to change the time to the desired minute in 10-minute increments. Press the **PROG** button to save. The temperature digits will begin flashing.
5. Press the **▲** or **▼** button to change the set point temperature to the desired setting in 1° F increments (0.5° C). Press the **PROG** button to save. The thermostat will now display the **DAY** set point time and temperature. Again, you will see the hour portion of the set point time and the **AM/PM** indicator will be flashing.
6. Follow steps 3 through 5 to set the set point times and temperatures for the **MORN**, **DAY**, **EVE** and **NIGHT** set points for the Weekday group in the **HEAT** mode.
7. After pressing the **PROG** button, you will enter the Weekend Program Group. The display will show **SA**, **SU** to indicate the Weekend group is being programmed. The hour portion of the **MORN** set point time and the **AM/PM** indicator will be flashing.
8. Follow steps 3 through 5 to set the set point times and temperatures for the **MORN**, **DAY**, **EVE** and **NIGHT** set points for the Weekend group in the **HEAT** mode.
9. Place the system switch in the **COOL** mode of operation. The display will show **COOL**. Follow steps 2 through 8 to program the set point times and temperatures for the Weekday and Weekend groups in the **COOL** mode.

**NOTE:** To erase all entered programs, current time of day, day of week and other user settings, gently press the **RESET** button using a paper clip or a small pencil tip. This will return all thermostat settings to their default values.

## 5 Additional Operation Features

### Review Set Temperature

1. Press and hold the **▲** or **▼** button. The current set point temperature will be displayed in place of the current room temperature, and the indicator **SET** will be displayed.
2. The display will return to normal operating mode when the **▲** or **▼** button is released. Continuing to hold the **▲** or **▼** button for 1 second or longer will allow the user to temporarily override the current programmed set point.

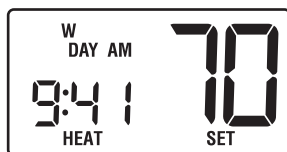

### Temporary Program Override

1. Press and hold **▲** or **▼** button for 1 second or longer. The entire display will flash once and the **SET** indicator will be displayed. Release the **▲** or **▼** button and press the **▲** or **▼** button again as desired to adjust the set temperature.
2. The display will return to normal operating mode after 15 seconds or you can press the **RETURN** button.
3. The program indicator (**MORN**, **DAY**, **EVE** or **NIGHT**) will be flashing in the display, indicating that a Temporary Program Override is in effect. The Temporary Program Override will reset when the next set point time occurs or after four hours—whichever comes first.

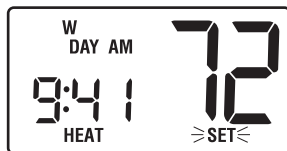

## 5 Additional Operation Features *cont.*

### Extended Hold (Vacation) Mode

1. Press the **HOLD** button to bypass the program schedule. The current set point temperature will be held either permanently or for 24 hours, depending on the setting selection made in section 4.
2. Press the **HOLD** button again to return the thermostat to the normal program operation.
3. The hold period will last until the hold is released as in step number 2 above, or is limited to 24 hours if the default was changed in the User Options Settings (see section 4).

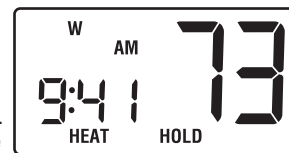

### Compressor Protection

This thermostat includes an automatic compressor protection feature to avoid potential damage to the cooling system from short cycling. This thermostat automatically provides a 5-minute delay after turning off the cooling system output to protect the compressor. This protection is also present in the heat mode of operation on single stage heat pump systems to protect the compressor.

**NOTE:** The installer can reset the thermostat and bypass the compressor protection features by pressing the **RESET** button. This will erase all entered programs, current time of day, day of week and other user settings and should only be used during installation for testing purposes or to reset a thermostat to regain normal operation. This will return all thermostat settings to their default values. The user will have to re-program all of the erased settings.

### Low Battery Detection and Replacement

This thermostat requires two (2) properly installed "AA" Alkaline batteries to maintain the system clock and to provide power for the thermostat if 24 volt AC power is not connected to the terminal block.

This thermostat is equipped with a low battery detection feature that constantly monitors the batteries during normal operating mode to determine whether they have sufficient power to provide proper operation.

When this feature determines that the battery status is low, a solid low battery indicator will appear in the display for 30 days. It is recommended that the batteries be replaced immediately to maintain system operation and / or clock settings. If the battery continues to be low, the icon will flash every 2 seconds for 30 days. After 30 days the battery indicator will start to flash every 1 second until the batteries are replaced.

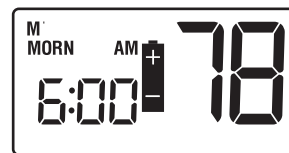

### Replacing the Batteries

1. Open the thermostat cover and locate the battery compartment door.
2. Remove the two "AA" alkaline batteries located in the battery compartment.
3. Install two new "AA" alkaline batteries into battery compartment. Make sure to match the positive (+) ends of the batteries with the positive (+) terminals located in the battery compartment.
4. Close battery compartment and verify that the low battery indicator does not appear in the display.

## 5 Additional Operation Features *cont.*

### Adaptive Recovery Mode (ARM™)

In order to maximize comfort and energy efficiency, this thermostat is equipped with an Adaptive Recovery Mode (ARM™). This feature minimizes the amount of time required by heating or cooling system to reach the new set point, after a setback period is completed. This assures your desired temperature is achieved at your set program times. In the model 2200, this feature also minimizes the use of second stage heating.

This feature activates when recovering room temperature from setback programs to comfort programs, so it will only take place when the current (heating) program set point temperature is lower than the upcoming program set point temperature, or the current (cooling) program set point temperature is higher than the upcoming program set point temperature.

During ARM™, room temperature is recovered gradually by turning on the heating or cooling before the end of the setback period. The set point temperature is changed to that of the upcoming comfort program temperature. The start time of recovery is based on the difference between the current room temperature and the upcoming comfort program set point temperature. The recovery to the upcoming set point starts 10 minutes before the upcoming set point time for each degree of temperature change required, up to a maximum of 2 hours.

ARM™ does not operate when the unit is in the HOLD mode, if the program is temporarily overridden, or has been turned off in the user settings.

### Filter Check Monitor (see section 4 for setting)

The Filter Check Monitor displays a reminder for required filter replacement or cleaning by flashing the **FILT** segment in the display. See instructions on your filter or heating/cooling unit for recommendations for interval setting.

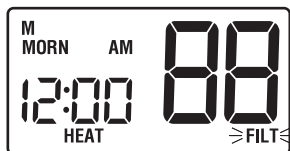

When the selected interval has been reached, and required cleaning or replacement has been performed, press the **RETURN** button in any normal mode to reset the timer and turn off the warning.

### Resetting the Thermostat

The Reset feature allows the user to completely reset the thermostat to register new manual switch settings.

1. To erase all entered programs, current time of day, day of week and other user settings, gently press the **RESET** button using a paper clip or a small pencil tip.
2. This will return all thermostat settings to their default values and register all new manual switch settings for proper operation.

### Non-Volatile Memory

In the event of a power failure, the Non-Volatile Memory feature allows all settings to be recovered, eliminating the need to reset temperature and differential settings. When AC power is restored after an outage, all settings are retrieved from memory and reinstated.

## 6 Troubleshooting

**Symptom:** *Thermostat does not turn on heating or cooling system.*

**Potential Solutions:** Check to see if **OFF** is shown in display. This indicates that the system is turned off at the thermostat. Move the system selector switch to the **HEAT** or **COOL** position. After the compressor short cycle protection 5-minute period expires the system should start.

Compressor protection feature may be in effect due to compressor short cycle conditions. See section 5.

Heating or cooling system may be malfunctioning. Call a professional service technician immediately to verify system operation.

**Symptom:** *Thermostat turns on heating instead of cooling or cooling instead of heating.*

**Potential Solution:** Check thermostat wiring to make sure that the heating and cooling stages are connected to the correct terminals on the wiring terminal block. See section 7.

**Symptom:** *Thermostat will not follow program set points.*

**Potential Solutions:** Check current time of day, day of week program settings. Make sure to verify **AM/PM** indicator is accurately displaying desired time settings. See section 4.

Check to see if **OFF** is shown in display. This indicates that the system is turned off at the thermostat. Move the system selector switch to the **HEAT** or **COOL** position. After the compressor short cycle protection period expires the system should start within several seconds.

Verify your program set point time entries. The heating and cooling programs utilize the same set point times, but have individual set point temperatures for the **MORN**, **DAY**, **EVE** and **NIGHT** set points. See section 4.

Thermostat program has been temporarily overridden and program indicator is flashing in the display. Press the **HOLD** button twice to return the thermostat to normal program operation or wait until next set point and the temporary override will expire.

Thermostat program is in Extended Hold (Vacation) Mode and **HOLD** is showing in display. Press **HOLD** button to release permanent hold and return the thermostat to normal program operation.

**Symptom:** *Thermostat turns heating or cooling system on too often or not often enough.*

**Potential Solution:** Increase or decrease first stage temperature differential setting as appropriate to provide the desired performance level. See section 4.

**Symptom:** *Low battery indicator is shown in thermostat display.*

**Potential Solution:** Replace batteries immediately to maintain proper system operation. See section 5.

**Symptom:** *OFF is shown in thermostat display and heating or cooling system will not start.*

**Potential Solution:** This indicates that the system is turned off at the thermostat. The thermostat must be in **HEAT** or **COOL** modes of operation to control the heating or cooling system. Move the system selector switch to the **HEAT** or **COOL** position.

## 6 Troubleshooting *cont.*

**Symptom:** *Thermostat display is blank.*

**Potential Solution:** It is possible that AC power is not present at the thermostat or the batteries are drained. Check fuse, circuit breaker and thermostat wiring as appropriate to verify AC power is available. Replace batteries before reprogramming thermostat. See section 5. If AC power is present, call a professional service technician to verify thermostat and system performance.

**Symptom:** *HI is shown in the thermostat display where the room temperature is normally displayed.*

**Potential Solutions:** The temperature sensed by the thermostat is higher than the 99° F (37° C) upper limit of the thermostat's display range. The display will return to normal after the sensed temperature lowers within the 40° to 99° F (5° to 37° C) display range. Turn on the cooling system or use other methods to lower the temperature accordingly.



This condition could occur from the system being turned off during an exceptionally warm period or upon installation when the thermostat has been stored for a long period of time in a warm vehicle or location prior to being installed.

**Symptom:** *LO is shown in the thermostat display where the room temperature is normally displayed.*

**Potential Solutions:** The temperature sensed by the thermostat is lower than the 40° F (5° C) lower limit of the thermostat's display range. The display will return to normal after the sensed temperature rises within the 40° to 99° F (5° to 37° C) display range. Turn on the heating system to raise the temperature as needed for comfort within the room.



This condition could occur from the system being turned off during a cold weather period or upon installation when the thermostat has been stored for a long period of time in a cold vehicle or location prior to being installed. The thermostat should be allowed to warm up prior to installation to allow proper heating control once installed.

**Symptom:** *Cannot program a set point temperature higher than 90° F (32° C).*

**Potential Solution:** This is above the normal thermostat temperature setting range of 45° to 90° F (7° to 32° C).

**Symptom:** *Cannot program a set point temperature lower than 45° F (7° C).*

**Potential Solution:** This is below the normal thermostat temperature setting range of 45° to 90° F (7° to 32° C).

**Symptom:** *Fan continues to run all the time whether the system is on or off.*

**Potential Solution:** Check that the fan control switch is in the **AUTO** position. This will allow the fan to run only when the heating or cooling system is turned on and running.

Check thermostat wiring to make sure that the fan control wiring is connected to the correct terminals on the wiring terminal block. See section 7.

## 6 Troubleshooting *cont.*

**Symptom:** *The room is too warm or too cold.*

**Potential Solution:** See section 4 of this manual to verify the current set point and make any changes that are necessary.

**Symptom:** *System turns on prior to the end of a setback period.*

**Potential Solution:** Thermostat is in Adaptive Recovery Mode. See section 5.

**Symptom:** *NO AUX SET is shown in the thermostat display (model 2200 only).*

**Potential Solution:** The thermostat (model 2200 only) is configured for a conventional system, and the system switch is in the **EM HEAT** position. The unit will still function in a conventional 2 stage HEAT mode, but the display will flash **NO AUX SET**. Move the system switch to the HEAT position.

## 7 Wiring Diagrams

### MODEL 2000: Single Stage Conventional Systems (Single Transformer)

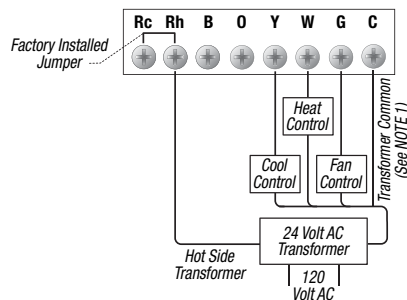

**NOTE:** 1. Transformer Common not required for battery-only operation of thermostat. 2. For heating or cooling only system, ignore opposite connection. 3. For 2-wire 24 Volt AC or 250mV - 750mV millivolt heating systems, ignore cooling connection and fan control.

### MODEL 2000: Single Stage Conventional Systems (Dual Transformer)

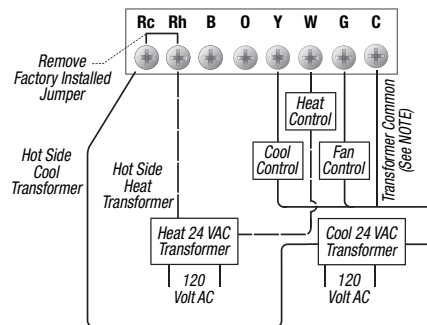

**NOTE:** Transformer Common not required for battery-only operation of thermostat.

## MODEL 2000: Single Stage Heat Pump System

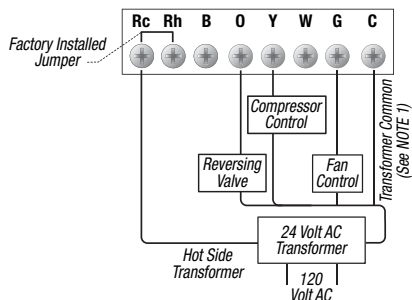

- NOTE:** 1. Transformer Common not required for battery-only operation of thermostat.  
2. For reversing valve active in heating, use B terminal instead of O terminal.

## MODEL 2200: Conventional Systems (Single Transformer)

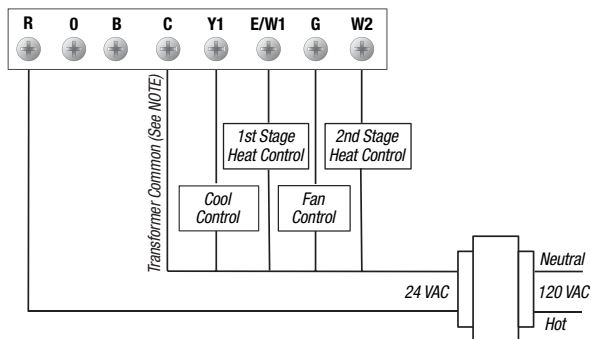

- NOTE:** Transformer Common not required for battery-only operation of thermostat.

## MODEL 2200: Wiring Diagram for 2 Stage Heat, 1 Stage Cool

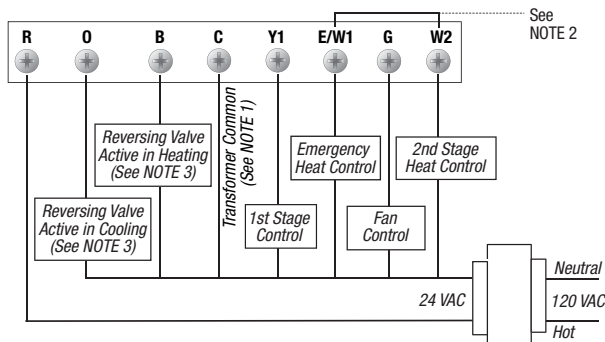

- NOTE:** 1. Transformer Common not required for battery-only operation of thermostat.  
2. Jumper is required to use Auxiliary Heat for both Second Stage and Emergency Heat on units without separate Emergency Heat and Auxiliary Heat terminals. 3. For units requiring reversing valve to be energized during heating, connect reversing valve to B terminal. For units requiring reversing valve to be energized during cooling, connect reversing valve to O terminal.

**5 YEAR**  
LIMITED  
WARRANTY

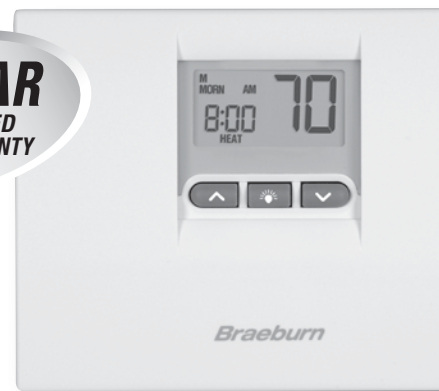

Store this  
booklet for  
future reference

Braeburn Systems LLC warrants each new Braeburn thermostat against any defects that are due to faulty material or workmanship for a period of five years after the original date of purchase by a professional service technician. This warranty and our liability does not apply to batteries, nor does it include damage to merchandise or the thermostat resulting from accident, alteration, neglect, misuse, improper installation or any other failure to follow Braeburn installation and operating instructions.

Braeburn Systems LLC agrees to repair or replace at its option any Braeburn thermostat under warranty provided it is returned postage prepaid to our warranty facility in a padded carton within the warranty period, with proof of the original date of purchase and a brief description of the malfunction. This limited warranty does not include the cost of removal or re-installation.

This warranty gives you specific legal rights and you may also have other rights that vary from state to state or province to province. Answers to any questions regarding our limited warranty may be obtained by writing our corporate offices.

**WARRANTY FACILITY:** Braeburn Systems LLC  
Attn: Warranty Department  
2215 Cornell Avenue  
Montgomery, IL 60538

# Braeburn®

Braeburn Systems LLC  
2215 Cornell Avenue • Montgomery, IL 60538  
Technical Assistance: [www.braeburnonline.com](http://www.braeburnonline.com)  
Call us toll-free: 866-268-5599 (U.S. Only)  
630-844-1968 (Outside the U.S.)